

A Study of Stochastic Resonance in the Periodically Forced Rikitake Dynamo

Chien-Chih Chen^{1, *} and Chih-Yuan Tseng²

(Manuscript received 8 March 2006, in final form 12 March 2007)

ABSTRACT

The geodynamo has widely been thought to be an intuitive and self-sustained model of the Earth's magnetic field. In this paper, we elucidate how a periodic signal could be embedded in the geomagnetic field via the mechanism of stochastic resonance in a forced Rikitake dynamo. Based on the stochastic resonance observed in the periodically forced Rikitake dynamo, we thus suggest a common triggering for geomagnetic reversal and glacial events. Both kinds of catastrophes may result from the cyclic variation of the Earth's orbital eccentricity.

(Key words: Stochastic resonance, Rikitake dynamo, Glaciation, Geomagnetic reversal)

1. INTRODUCTION

The Reynolds number of the Earth's liquid core is believed to be sufficiently large ($\sim 10^8$) that the flow of electrical currents in the liquid core is undoubtedly turbulent (e.g., Glatzmaier 2002). The pattern of the Earth's magnetic fields is thus very complex (Glatzmaier and Roberts 1995). Because of such a great complexity relatively simple disk dynamos (Rikitake 1958; Chillingworth and Holmes 1980) had been for a time proposed as analog models, and one of them is the Rikitake dynamo of two-disks in which the current produced by one disk energizes the other disk (Fig. 1) (Rikitake 1958). The Rikitake dynamo was originally proposed in 1950s

¹ Department of Earth Sciences and Graduate Institute of Geophysics, National Central University, Chung-Li, Taiwan, ROC

² Department of Physics, National Central University, Chung-Li, Taiwan, ROC

* *Corresponding author address:* Prof. Chien-Chih Chen, Department of Earth Sciences and Graduate Institute of Geophysics, National Central University, Chung-Li, Taiwan, ROC;

E-mail: chenc@ncu.edu.tw

doi: 10.3319/TAO.2007.18.4.671(T)

as an elegant prototype for explaining geomagnetic polarity reversal (Rikitake 1958) though, nowadays, is not regarded by most geophysicists as an accurate model of the Earth's magnetic field (e.g., Buffett 2000). While the actual Earth's dynamo is absolutely a high-order physical system with very large degrees of freedom (Glatzmaier and Roberts 1995; Buffett 2000; Hoyng et al. 2002), the Rikitake dynamo is only a low-order analog with few degrees of freedom that oversimplifying the electrical current flows in the liquid outer core. Significant modifications have been made to improve the accuracy of simulating the Earth's magnetic field (e.g., Glatzmaier and Roberts 1995; Hoyng et al. 2002).

Although the Rikitake model only represents a special case for the real geodynamo, it is absolutely a paradigm for the *long-term* behavior of the geomagnetic field. Therefore, according to the inductive principle, one can induce from some special cases that characterize part of the real phenomena to a general model. Such a philosophy is adopted everywhere in physics. Since the Rikitake model reveals the long-term behavior of the geomagnetic field, a real geodynamo model should reduce to the Rikitake model under some conditions. Namely, one can develop a theory based on the Rikitake model for investigating the geodynamo with certain degrees of confidence. We thus, in the present paper, utilize such a conceptual Rikitake dynamo to investigate the possibility of a new phenomenon of *stochastic resonance* (SR) in the geomagnetic field. The Rikitake dynamo turns out to be a good and efficient starting point for our

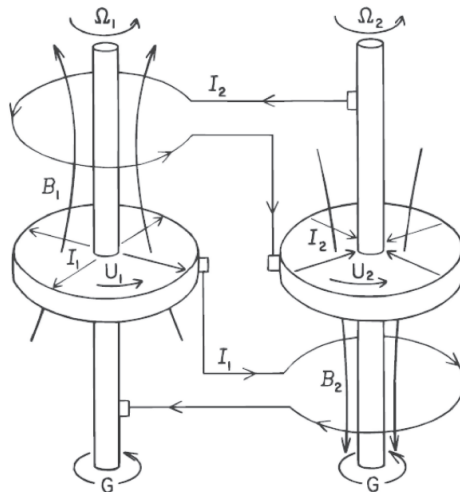

Fig. 1. Illustration of the Rikitake two-disk dynamo (after Turcotte 1997). The applied torque G drives the shafts and the metallic disks to rotate at the angular velocities of Ω_1 and Ω_2 in a counterclockwise direction. The currents I_1 and I_2 in the coils generate the magnetic fields B_1 and B_2 . The interaction between the magnetic fields and the rotating disks further generates induced currents, thus maintaining the magnetic fields of the dynamo.

purpose of exploring the SR phenomenon in the geomagnetic field. If SR could be confirmed as occurring within a low-order analog of the Earth's magnetic field, it must also be a real possibility within the Earth's actual high-order geomagnetic system. Such a situation is analogous to that encountered in studying the mechanism of geomagnetic polarity reversal in the 1950s (Turcotte 1997). At the end of this paper, we propose an interesting implication for the observed SR phenomenon to explain the coincident temporal correlation between geomagnetic reversal and glacial events, for which both have a common quasi-period of about 100 kyr (e.g., Yokoyama and Yamazaki 2000).

Over the last two decades, the SR phenomenon has continuously attracted considerable attention of scientists (e.g., Benzi et al. 1981, 1982; Collins et al. 1995; Wiesenfeld and Moss 1995; Dykman and McClintock 1998). The term *stochastic resonance* describes the group of effects in a nonlinear system whereby the response of the system to the weak external, periodic signal is remarkably amplified by an increase in noise intensity. This idea was independently introduced by Benzi et al. (1981) and Nicolis (1982) in an attempt to explain the peculiar phenomenon of periodic recurrence in the Earth's ice ages. SR has become a well-established fundamental phenomenon occurring in various nonlinear systems (e.g., Wiesenfeld and Moss 1995; Gammaitoni et al. 1998). It is also well known that deterministic chaos resembles the features of noise on a coarse-grained time scale (Gammaitoni et al. 1998; Arai et al. 2004). Therefore, for dynamical systems with deterministic chaos, no external source providing randomness is necessary. It is thus natural that SR can be observed (e.g., Carroll and Pecora 1993; Arai et al. 2004) in various deterministic chaotic systems without the presence of noise, the Rikitake dynamo for example.

2. THE PERIODICALLY FORCED RIKITAKE DYNAMO

In the Rikitake dynamo of two-disks (Fig. 1) let us assume currents I_1 and I_2 passing through two current loops in each dynamo, respectively. The coupled nonlinear differential equations governing the behavior of the Rikitake dynamo are:

$$L \frac{dI_1}{dt} + RI_1 = M\Omega_1 I_2 \quad , \quad (1)$$

$$L \frac{dI_2}{dt} + RI_2 = M\Omega_2 I_1 \quad , \quad (2)$$

$$C \frac{d\Omega_1}{dt} = G - MI_1 I_2 \quad , \quad (3)$$

$$C \frac{d\Omega_2}{dt} = G - MI_1 I_2 \quad , \quad (4)$$

where L and R are the self-inductance and the resistance in either circuit, respectively. M is the mutual inductance between the circuits and the electrically conducting disks. C is the moment of inertia of each dynamo. The applied torque G drives the shafts of two disks, making them rotate with angular velocities Ω_1 and Ω_2 , respectively. Notice that, essentially, the first two equations describe the time evolution of the electrical energies in two dynamos and the last two equations for the force (torque) balances.

The behavior of the Rikitake dynamo is found to be chaotic. Extensive studies of this system have been carried out by many researchers in the last few decades, mainly for modeling the polarity reversals of the Earth's magnetic field (Rikitake 1958; Cook and Roberts 1970; Chillingworth and Holmes 1980; Ito 1980; Hoshi and Kono 1988; Cortini and Barton 1994), but never for the relevant aspect of *stochastic resonance* (SR) intrinsic in the dynamo when subjected to a periodic driving force. There are various mechanisms (e.g., Jocab 1994; Kono and Roberts 2002) producing a periodic force which could be applied to the dynamo model, for instance, the effects of the Earth's orbital eccentricity, the moment-of-inertia, and the precession. While most geophysicists prefer buoyancy as the primary driving force for the motions in the liquid core and ignore the external tiny periodic forces, they will also concede that the periodically precessional forces are probably large enough to be treated seriously in a dynamo model (e.g., Tilgner 2005). Thus, for investigating the response of the periodically forced Rikitake dynamo, we consider a relevant periodic torque applying to the disk shafts of the dynamos. Therefore we may modify the above equations (3) and (4) to the following forms:

$$C \frac{d\Omega_1}{dt} = G - MI_1I_2 + A \cos\left(\frac{2\pi t}{T}\right) , \quad (5)$$

$$C \frac{d\Omega_2}{dt} = G - MI_1I_2 + A \cos\left(\frac{2\pi t}{T}\right) , \quad (6)$$

where A and T denote the amplitude and period of the external driving torque, respectively. We numerically solved this coupled system of ordinary differential equations with an explicit fourth-order routine of the Runge-Kutta method (Press et al. 1992), which is simple, robust and widely used for the numerical solution of differential equations. After obtaining numerical solutions of simultaneous equations (1), (2), (5), and (6), we arbitrarily took the simulated magnetic field to be normal when the value of I_1 or I_2 is positive and to be reversed otherwise.

3. RESULTS: STOCHASTIC RESONANCE IN THE PERIODICALLY FORCED RIKITAKE DYNAMO

We generated large numbers of synthetic geomagnetic reversal records, in general, consisting of more than several hundreds of reversal events. Then, we counted the time duration τ of these synthetic polarity intervals and binned them according to their duration length. Figure 2 shows a duration histogram for the modeled geomagnetic epochs from the Rikitake dynamo

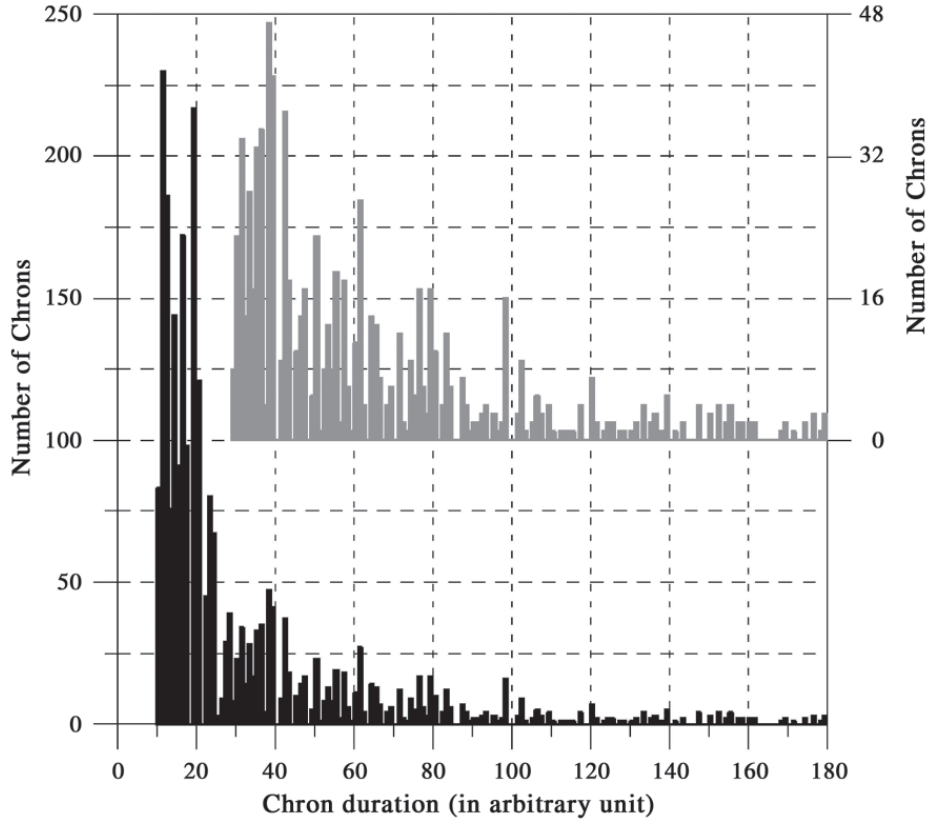

Fig. 2. Duration histogram of simulated magnetic chrons for the Rikitake dynamo subject to an external force with a periodicity of 20. A vertical exaggeration for the distribution of chron durations larger than 30 is shown in the upper panel. The occurrence possibility of the polarity durations of integer multiples of the driving force largely rises because of the SR effect in the forced Rikitake system.

subjected to a periodic force of $T = 20$ units, arbitrarily chosen in our numerical integration. It is obvious in Fig. 2 that many peaks appear at the polarity duration equal to integer multiples of the period of the driving force, i.e., $\tau = 40, 60, 80, 100$, and so forth. For comparison, Fig. 3 plots the distribution of the polarity interval lengths for the actual Earth's magnetic field (Cande and Kent 1995; Ogg 1995; Consolini and De Michelis 2003). A striking feature in Fig. 3 is the series of nearly equally spaced peaks with a spacing of about 100 kyr.

Furthermore, inspired by the multi-peaked residence-time distribution introduced by Gammaitoni et al. (1989), we investigated the occurrence of a resonant process by changing the amplitude of the driving periodic force. There are two standard ways to characterize the

occurrence of SR: the power spectral density of a specific periodic response and the strength of the first peak in the residence-time distribution. While studying the strength of the first peak in the residence-time distribution has become fashionable and useful in the SR case of tuning the frequency of the driving force, observation based on the power spectrum is intuitively meaningful and readily measurable (Gammaitoni et al. 1998). By exploring the spectral power of a periodic response with the frequency approximately equal to that of the external periodic force, Benzi et al. (1981, 1982) originally formulated the concept of SR as a resonant-like dependence of the spectral amplitude on the noise intensity. The SR of concern in this study was realized by changing the amplitude of the driving force, instead of tuning its frequency. The effect of changing the amplitude of the periodic force is equivalent to and simpler than the change in the intrinsic noise intensity of the chaotic dynamo. Our result shown in Fig. 4 is the calculated resonant-like dependence of the spectral power on the amplitude of the driving force. A short conclusion can thus be made based on two abovementioned discoveries (Figs. 2, 4). Our simulation does show the occurrence of a *bona-fide* SR in the periodically forced Rikitake dynamo.

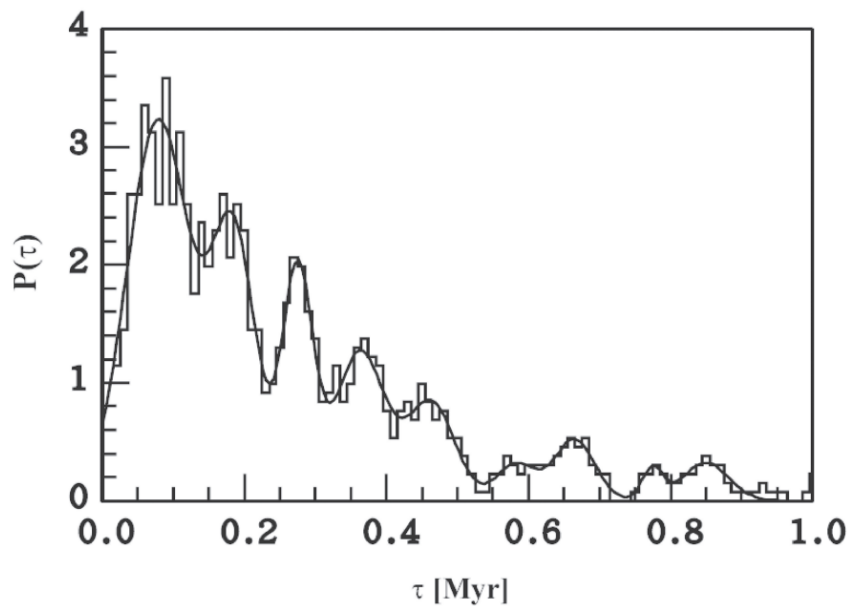

Fig. 3. Normalized distribution function of the durations of the Earth's magnetic chrons (after Consolini and De Michelis 2003). The solid line refers to a nonlinear best fit using a superposition of nine Gaussian functions and gives the estimated, reasonable peak positions. The feature of a series of peaks, which are uniformly spaced out about 100 kyr apart, can be recovered in the forced Rikitake dynamo, thus strongly suggesting the SR phenomenon in the geomagnetic field. The data of geomagnetic polarity intervals was compiled from Cande and Kent (1995) and Ogg (1995).

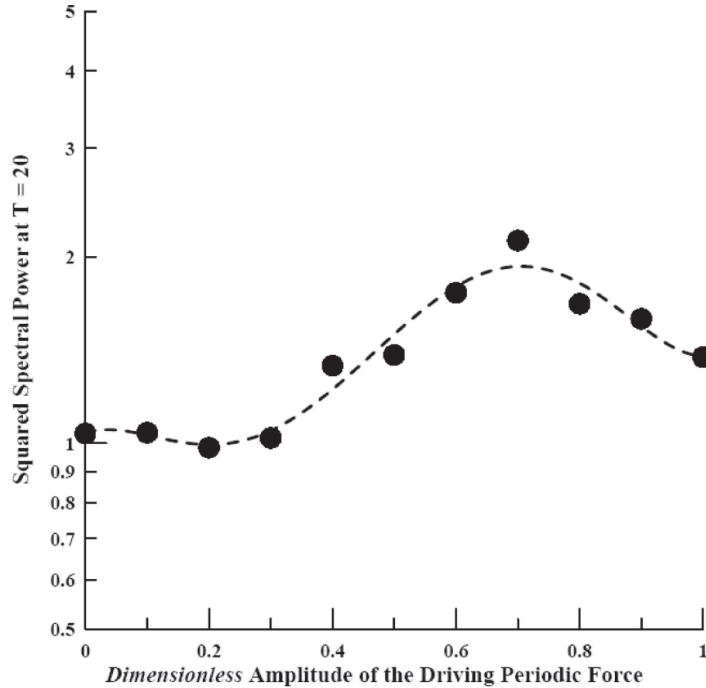

Fig. 4. Plot of squared spectral power $|\tilde{I}_1(f \sim 0.05)|^2$ versus *dimensionless* amplitude, A , of external driving in the forced Rikitake dynamo. $\tilde{I}_1(f)$ is the Fourier transform of $I_1(t)$. Note that the effect of changing the amplitude of the driving force is equivalent to a change in the intrinsic noise intensity of the dynamo. A resonant-like peak appeared at $A \sim 0.7$ confirming the occurrence of SR in our model. The best-fitting line (dash line) is drawn for the reader's convenience.

4. DISCUSSION

The physical picture emerging from our simulation of the forced Rikitake dynamo is that SR may occur in the Rikitake dynamo due to a subtle change in the external driving torque. We note that in our simulation the variation in the angular velocity of the forced Rikitake dynamo is about 15% more than the unforced Rikitake system. However, we emphasize that one condition other than the noise-magnitude matching for SR is essentially the “time-scale matching condition”, that is the period of the driving force approximately equals the double of the noise-induced escape time. The triggering of SR needs not to be the noise level matching one threshold value. Therefore, one can just focus on the “time-scale matching condition” when the noise magnitude is hard to identify. For more detail readers may refer to Gammaitoni et al. (1998) and many published articles talking about SR as well.

5. CONCLUDING REMARK

Since 1960s, there has been continued debate over the relationship between geomagnetic reversals and glaciations (Malkus 1968; Doake 1977; Kent and Opdyke 1977; Chave and Denham 1979; Rampino 1979; Kent 1982; Jacobs 1994; Channell et al. 1998; Guyodo and Valet 1999; Yokoyama and Yamazaki 2000; Yamazaki and Oda 2002). A detailed description of this debate is included in the book by Jacobs (1994). Even though there exists ample observational evidence supporting the concept of the magnetic field being perhaps modulated by climate change, the conservatives prefer explanation of contamination in the magnetic record of sediments. We think that the triggering mechanism is absolutely crucial to settling this issue. So far no theoretical analysis can explain the coincident temporal correlation between the geomagnetic reversal and glacial events yet, for which both have a quasi-period of about 100 kyr, although there exists a good deal of observational evidence for such a correlation.

Here in this paper we elucidate how a quasi-periodic signal could be embedded in the geomagnetic field by means of the mechanism of SR in a periodically forced Rikitake dynamo. As we demonstrate in this paper, when SR occurs in the forced Rikitake system, it highly increases the occurrence possibility of magnetic chrons with the durations of the odd and/or even multiples of half the period of the extra torque (Fig. 2) (Gammaitoni et al. 1994; Arai et al. 2004). Thus, the duration distribution of real geomagnetic chrons (Fig. 3) and power-spectrum dependence on the amplitude of the periodic force (Fig. 4) imply that the extra torque must be associated with a rotational force of about 100000-year periodicity. Our work presented in this paper thus establishes a physically plausible triggering mechanism of SR for geomagnetic intensity variation with a periodic signal. We thus suggest a common triggering *via* the SR effect of the Earth's orbital eccentricity for geomagnetic reversal and glacial events. We note that the pioneering papers on SR by Benzi et al. (1981, 1982) also attempted to explain the presence of a 100-kyr periodicity in the Earth's ice ages *via* the SR phenomenon of orbital forcing in the climatic system. Therefore, our demonstration of stochastic resonance in the periodically forced Rikitake dynamo provides the first theoretical evidence for an *indirect* relationship between two kinds of catastrophes in Earth's history.

Acknowledgements The authors highly appreciate one anonymous reviewer and Prof. Chiou-Fen Shieh for their helpful suggestions that greatly improved our manuscript. This work was supported by the Graduate Institute of Geophysics and the College of Earth Sciences at NCU, and the National Science Council of ROC.

REFERENCES

- Arai, K., S. Mizutani, and K. Yoshimura, 2004: Deterministic stochastic resonance in a Rössler oscillator. *Phys. Rev. E*, **69**, 026203.
- Benzi, R., A. Sutera, and A. Vulpiani, 1981: The mechanism of stochastic resonance. *J. Phys. A*, **14**, L453-L457.

- Benzi, R., G. Parisi, A. Suter, and A. Vulpiani, 1982: Stochastic resonance in climatic change. *Tellu*, **34**, 10-16.
- Buffett, B. A., 2000: Earth's core and the geodynamo. *Science*, **288**, 2007-2012.
- Cande, S. C., and D. V. Kent, 1995: Revised calibration of the geomagnetic polarity timescale for the Late Cretaceous and Cenozoic. *J. Geophys. Res.*, **100**, 6093-6095.
- Carroll, T. L., and L. M. Pecora, 1993: Stochastic resonance and crises. *Phys. Rev. Lett.*, **70**, 576-579.
- Channell, J. E. T., D. A. Hodell, J. McManus, and B. Lehman, 1998: Orbital modulation of the Earth's magnetic field intensity. *Nature*, **394**, 464-468.
- Chave, A. D., and C. R. Denham, 1979: Climatic changes, magnetic intensity variations, and fluctuations of the eccentricity of the Earth's orbit during the past two million years and a mechanism which may be responsible for the relationship: A discussion. *Earth Planet. Sci. Lett.*, **44**, 150-152.
- Chillingworth, D. R. J., and P. J. Holmes, 1980: Dynamical systems and models for reversals of the Earth's magnetic field. *Math. Geol.*, **12**, 41-59.
- Collins, J. J., C. C. Chow, and T. T. Imhoff, 1995: Stochastic resonance without tuning. *Nature*, **376**, 236-238.
- Consolini, G., and P. De Michelis, 2003: Stochastic resonance in geomagnetic polarity reversals. *Phys. Rev. Lett.*, **90**, 058501.
- Cook, A. E., and P. H. Roberts, 1970: The Rikitake two-disk dynamo system. *Proc. Camb. Phil. Soc.*, **68**, 547-569.
- Cortini, M., and C. C. Barton, 1994: Chaos in geomagnetic reversal records: A comparison between Earth's magnetic field data and model disk dynamo data. *J. Geophys. Res.*, **99**, 18021-18033.
- Doake, C. S. M., 1977: A possible effect of ice ages on the Earth's magnetic field. *Nature*, **267**, 415-417.
- Dykman, M. I., and P. V. E. McClintock, 1998: What can stochastic resonance do? *Nature*, **391**, 344.
- Gammaitoni, L., F. Marchesoni, E. Menichella-Saetta, and S. Santucci, 1989: Stochastic resonance in bistable systems. *Phys. Rev. Lett.*, **62**, 349-352.
- Gammaitoni, L., F. Marchesoni, and S. Santucci, 1994: Stochastic resonance without symmetry breaking. *Phys. Lett. A*, **195**, 116-120.
- Gammaitoni, L., P. Hänggi, P. Jung, and F. Marchesoni, 1998: Stochastic resonance. *Rev. Mod. Phys.*, **70**, 223-287.
- Glatzmaier, G. A., and P. H. Roberts, 1995: A three-dimensional self-consistent computer simulation of a geomagnetic field reversal. *Nature*, **377**, 203-209.
- Glatzmaier, G. A., 2002: Geodynamo simulations - How realistic are they? *Annu. Rev. Earth Planet. Sci.*, **30**, 237-257.
- Guyodo, Y., and J. P. Valet, 1999: Global changes in intensity of the Earth's magnetic field during the past 800 kyr. *Nature*, **399**, 249-252.
- Hoshi, M., and M. Kono, 1988: Rikitake two-disk dynamo system: Statistical properties and growth of instabilities. *J. Geophys. Res.*, **93**, 11643-11654.

- Hoyng, P., D. Schmitt, and M. A. J. H. Ossendrijver, 2002: A theoretical analysis of the observed variability of the geomagnetic dipole field. *Phys. Earth Planet. Inter.*, **130**, 143-157.
- Ito, K., 1980: Chaos in the Rikitake two-disk dynamo system. *Earth Planet. Sci. Lett.*, **51**, 451-456.
- Jacobs, J. A., 1994: *Reversals of the Earth's Magnetic Field*, 2nd Ed., Cambridge Univ. Press, Cambridge.
- Kent, D. V., and N. D. Opdyke, 1977: Paleomagnetic field intensity variation recorded in a Brunhes epoch deep-sea sediment core. *Nature*, **266**, 156-159.
- Kent, D. V., 1982: Apparent correlation of paleomagnetic intensity and climatic records in deep-sea sediments. *Nature*, **299**, 538-539.
- Kono, M., and P. H. Roberts, 2002: Recent geodynamo simulations and observations of the geomagnetic field. *Rev. Geophys.*, **40**, 1013, doi: 10.1029/2000RG000102.
- Malkus, W. V. R., 1968: Precession of the Earth as the cause of geomagnetism. *Science*, **160**, 259-264.
- Nicolis, C., 1982: Stochastic aspects of climatic transitions - response to a periodic forcing. *Tellus*, **34**, 1-9.
- Ogg, J. G., 1995: Magnetic polarity time scale of the Phanerozoic. In: Ahrens, T. J. (Ed.), *Global Earth Physics: A Handbook of Physical Constants*, AGU, Washington, DC, 240-270.
- Press, W. H., B. P. Flannery, S. A. Teukolsky, and W. T. Vetterling, 1992: *Numerical Recipes in FORTRAN: The Art of Scientific Computing*, 2nd Ed., Cambridge Univ. Press, Cambridge.
- Rampino, M. R., 1979: Possible relationships between changes in global ice volume, geomagnetic excursions, and the eccentricity of the Earth's orbit. *Geology*, **7**, 548-587.
- Rikitake, T., 1958: Oscillations of a system of disk dynamos. *Proc. Camb. Phil. Soc.*, **54**, 89-105.
- Tilgner, A., 2005: Precession driven dynamos. *Phys. Fluids*, **17**, 034104.
- Turcotte, D. L., 1997: *Fractals and Chaos in Geology and Geophysics*, 2nd Ed., Cambridge Univ. Press, Cambridge.
- Wiesenfeld, K., and F. Moss, 1995: Stochastic resonance and the benefits of noise: From ice ages to crayfish and SQUIDS. *Nature*, **373**, 33-36.
- Yamazaki, T., and H. Oda, 2002: Orbital influence on Earth's magnetic field: 100000-year periodicity in inclination. *Science*, **295**, 2435-2438.
- Yokoyama, Y., and T. Yamazaki, 2000: Geomagnetic paleointensity variation with a 100 kyr quasi-period. *Earth Planet. Sci. Lett.*, **181**, 7-14.
-
- Chen, C. C., and C. Y. Tseng, 2007: A study of stochastic resonance in the periodically forced Rikitake dynamo. *Terr. Atmos. Ocean. Sci.*, **18**, 671-680, doi: 10.3319/TAO.2007.18.4.671(T).